

HEAT AIR Z-Bracket Installation - AK1819B

Please refer to Heat Air operating and installation instructions for a comprehensive guide to heater operation and installation.

Veuillez vous reporter aux instructions d'utilisation et d'installation de Heat Air pour un guide complet sur le fonctionnement et l'installation du réchauffeur.

Consulte las instrucciones de uso y de instalación de Heat Air para una guía completa sobre el funcionamiento y la instalación del conductor.

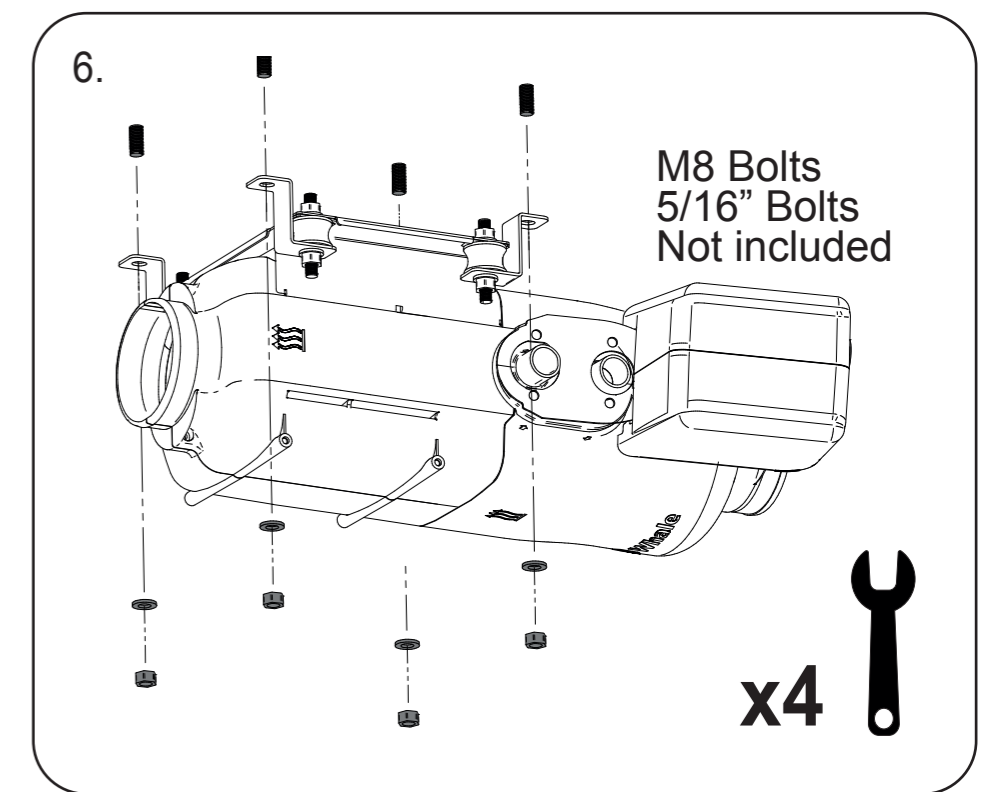
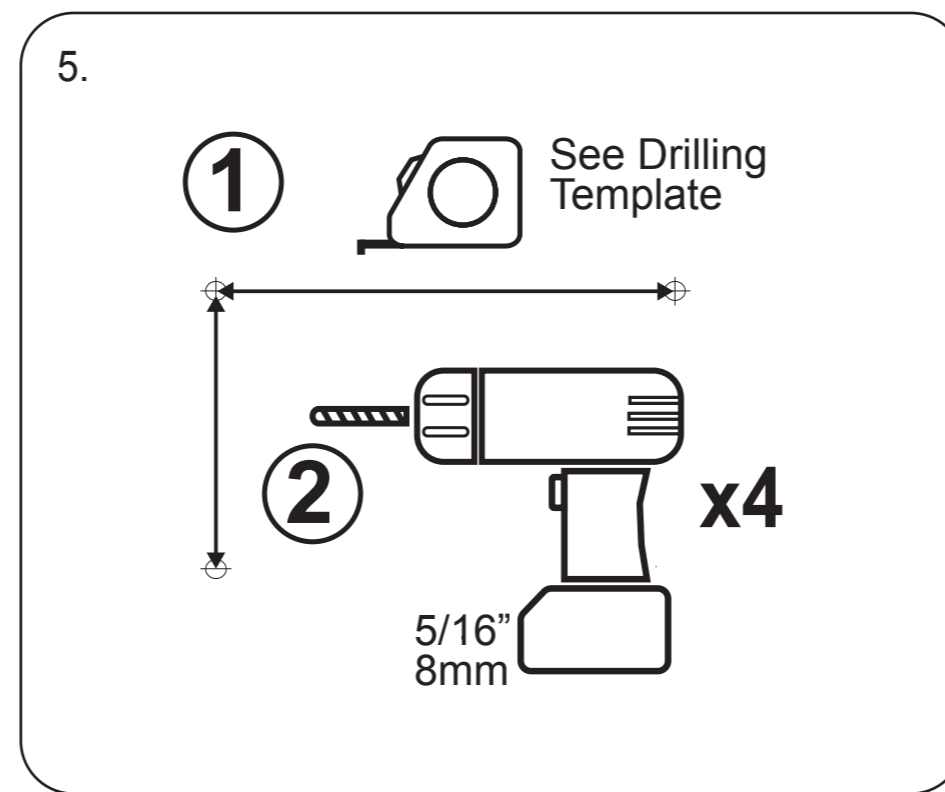
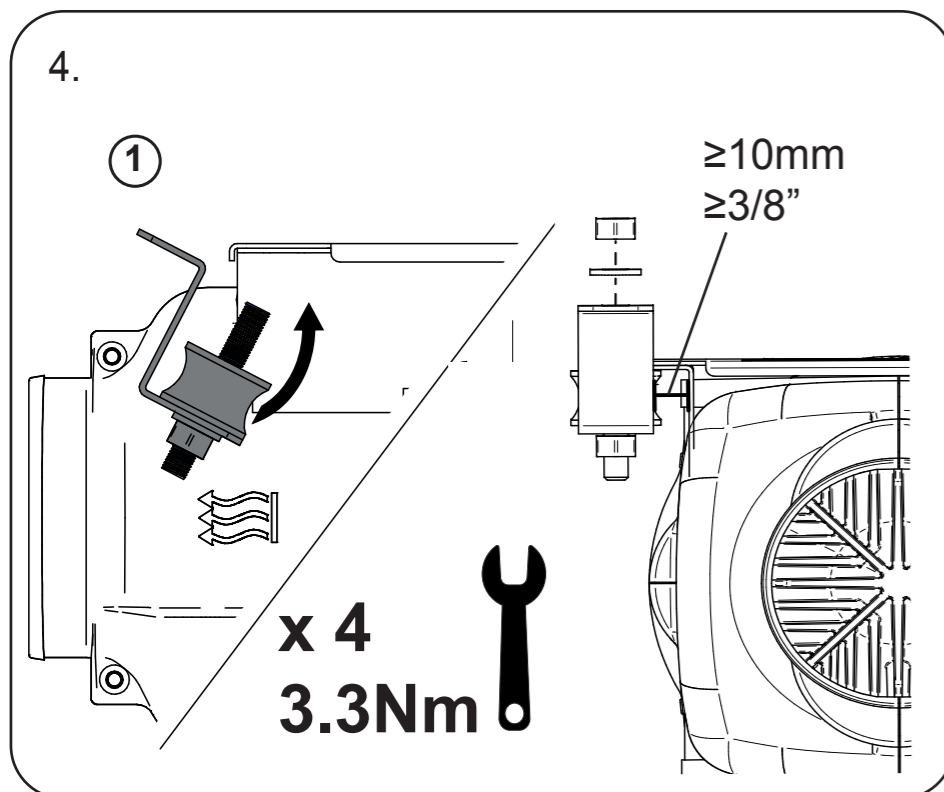
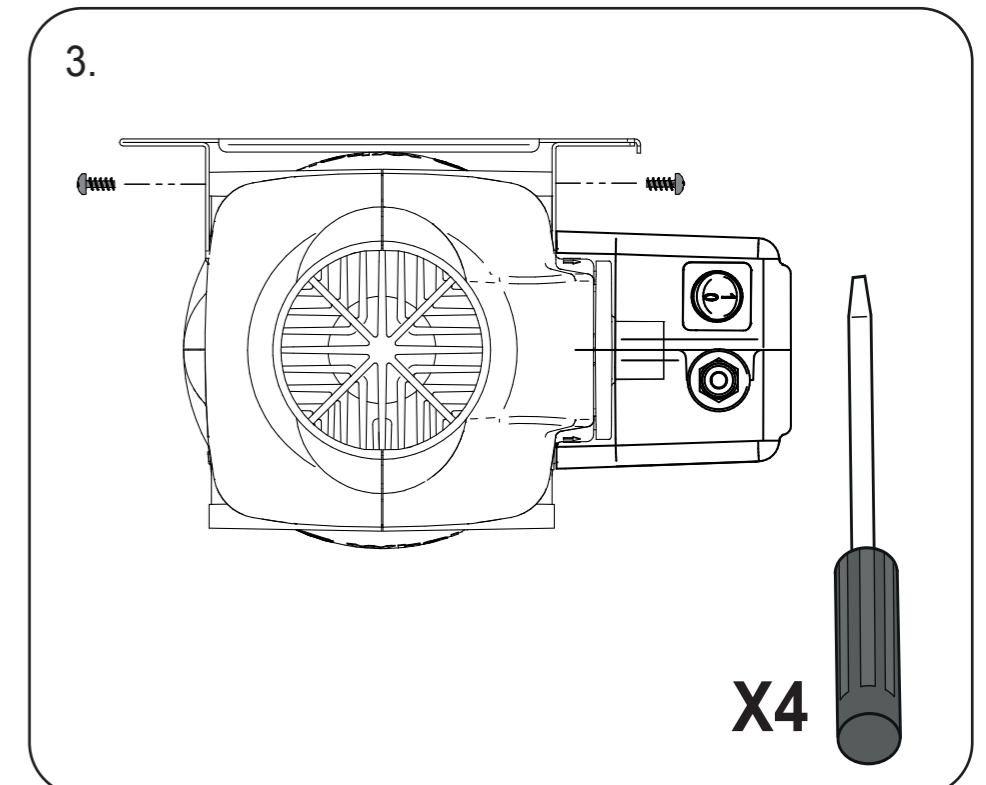
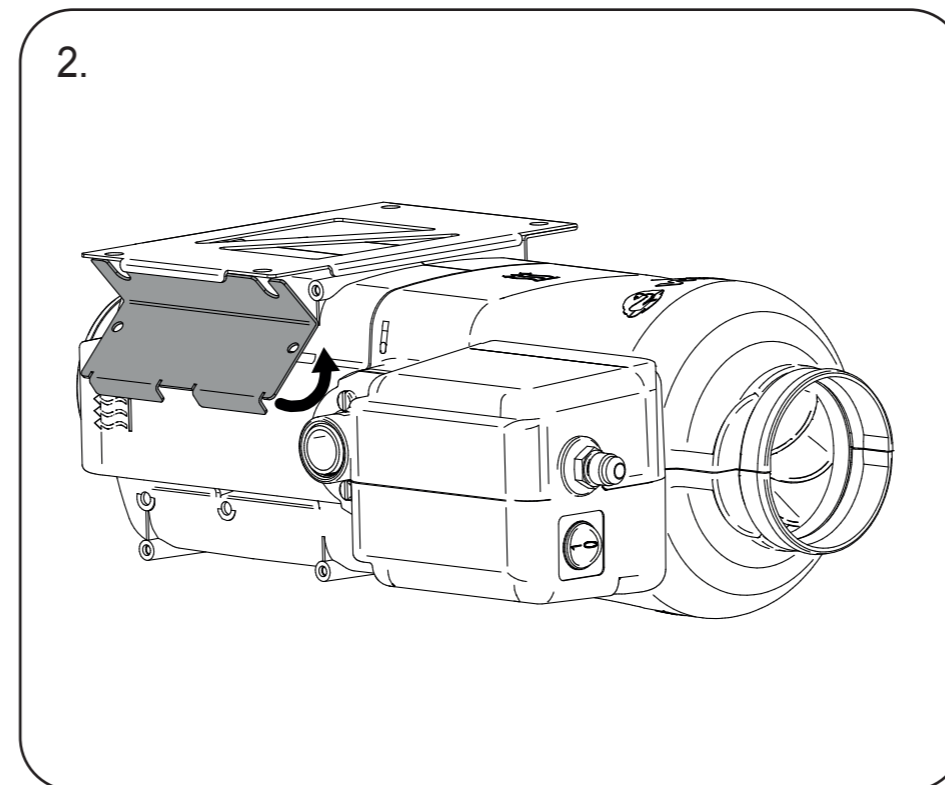
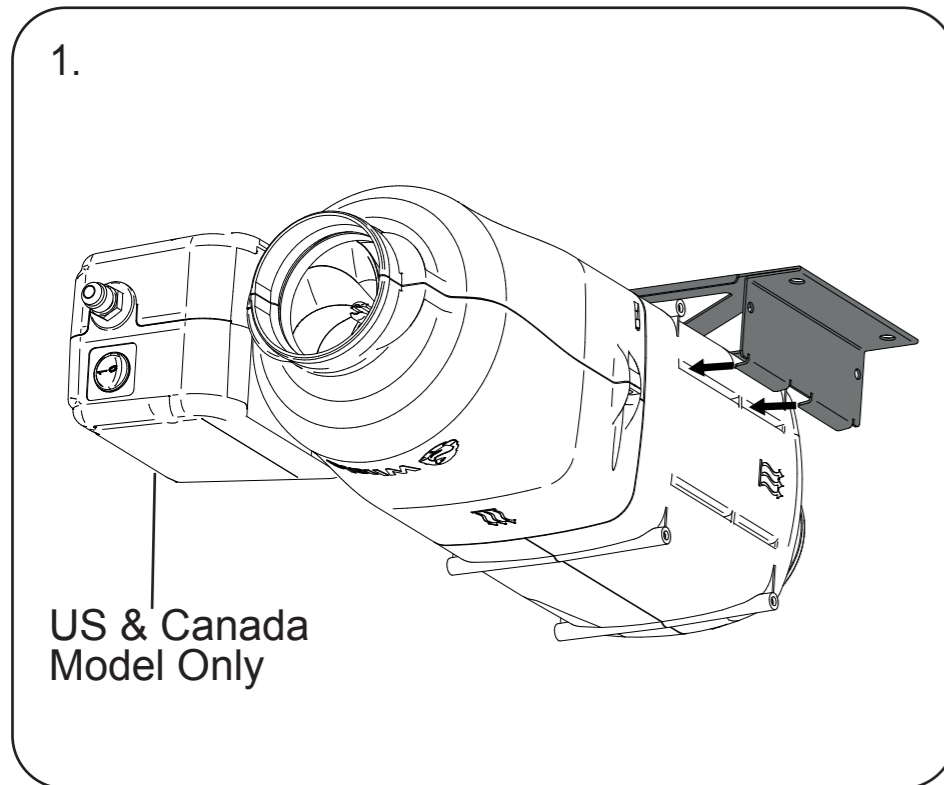

HEAT AIR Z-Bracket Drill Template

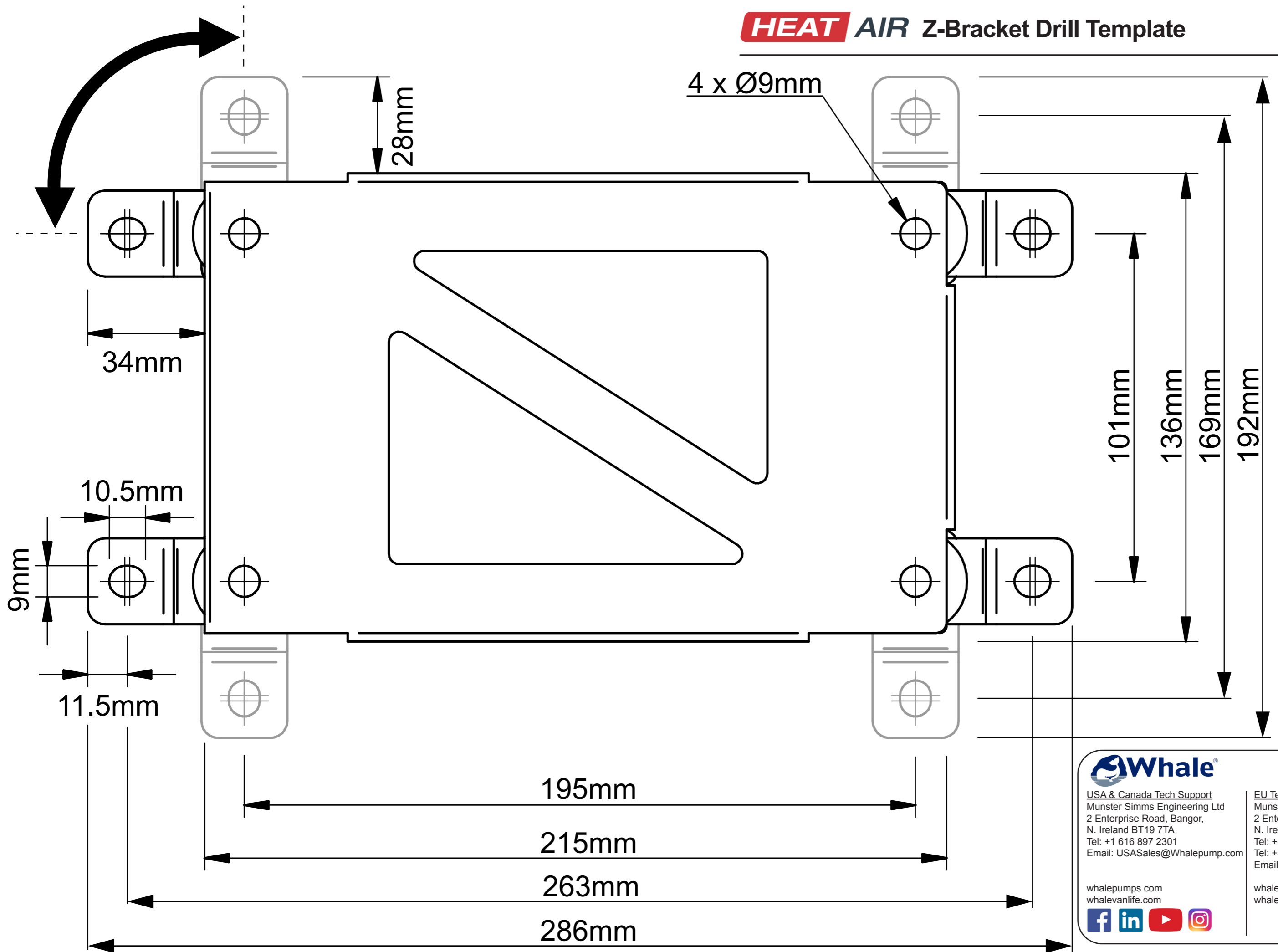

USA & Canada Tech Support
Munster Simms Engineering Ltd
2 Enterprise Road, Bangor,
N. Ireland BT19 7TA
Tel: +1 616 897 2301
Email: USASales@Whalepump.com

EU Tech Support
Munster Simms Engineering Ltd
2 Enterprise Road, Bangor,
N. Ireland BT19 7TA
Tel: +44 (0)345 9090 911
Tel: +44 (0)28 9127 0531
Email: info@Whalepump.com

whalepumps.com
whalevanlife.com



whalepumps.com
whalevanlife.com